

冠助 / 国土交通省L形タイプ

◇断面図

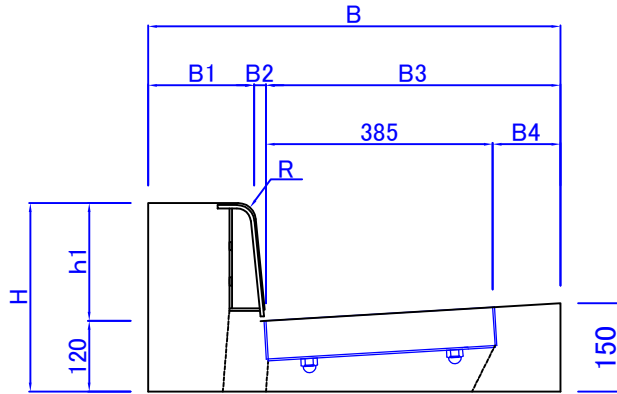

◇平面図

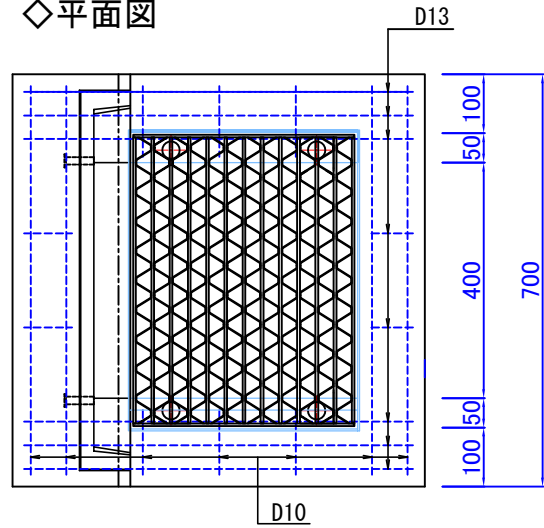

◇規格表

呼び名		寸法表(mm)								重量 (kg)
		H	h1	B	B1	B2	B3	B4	R	
国土交通省L形	I型	270	150	650	150	15	485	103	20	145
	I型665	270	150	665	150	15	485	115	20	150
	II型	320	200	700	180	20	500	115	30	154



冠助 / 都型 街きよます縁塊

◇断面図

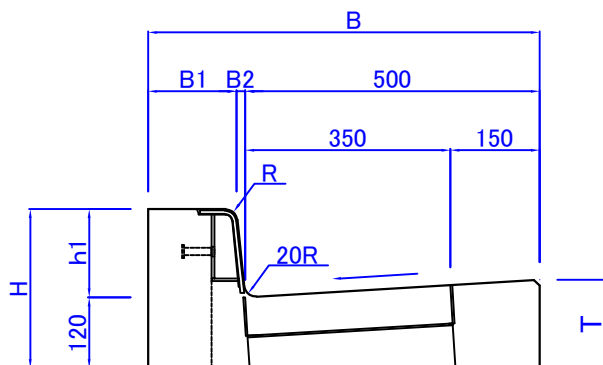

◇平面図

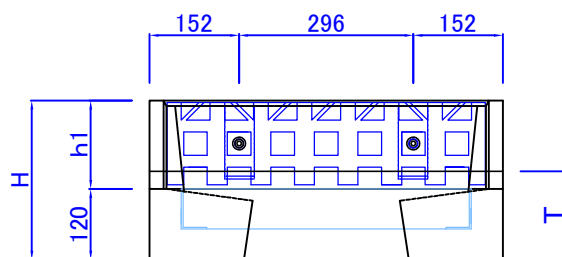
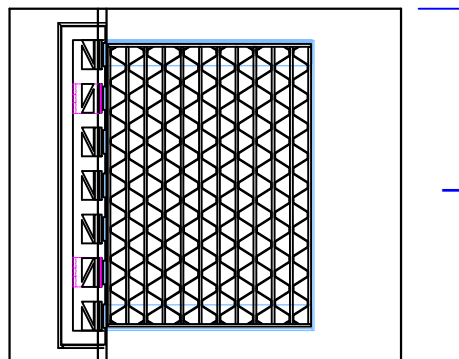

◇規格表

呼び名		寸法表(mm)								重量 (kg)	
		H	h1	B	B1	B2	%	T	R		L
街渠用集水柵	155-10%	270	150	665	150	15	10	170	20	600	113
	155-6%	270	150	665	150	15	6	150	20	600	108
	155SF	270	150	680	150	15	6	150	20	600	112
	205A	320	200	700	180	20	5	145	30	600	130



冠助 / 都型 L型集水枳

◇L集250

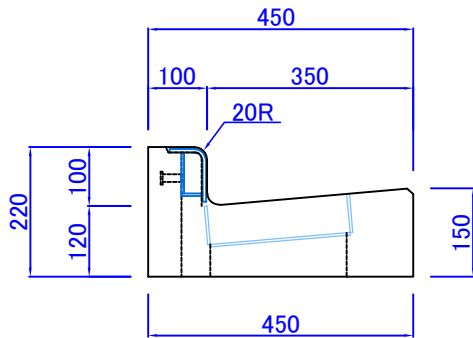

◇L集300 ○

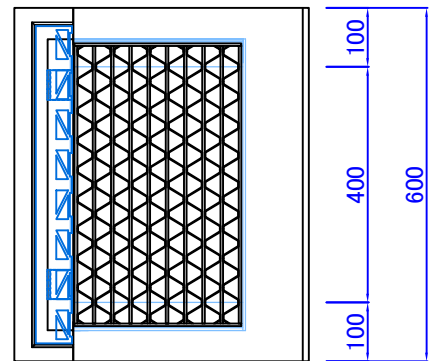
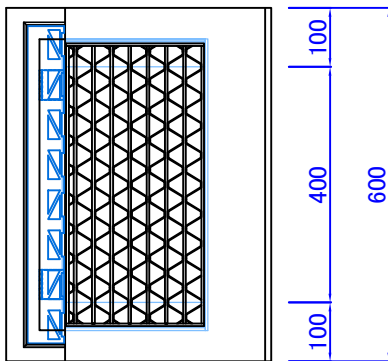
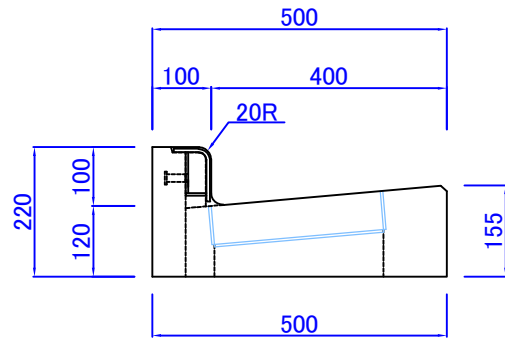

冠助 / 歩車道境界ブロック

◇断面図

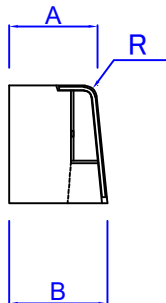

◇平面図

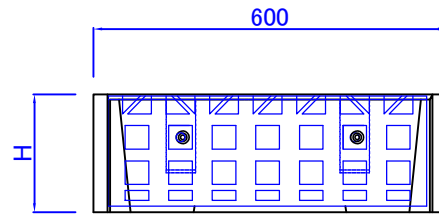

◇規格表

呼び名	寸法表(mm)					重量 (kg)
	A	B	H	R		
冠助 / 歩車道境界ブロック	A	150	170	200	20	35
	B	180	205	250	30	51
	C	180	210	300	30	65